

# **E**BLOCKS<sup>®</sup>

Quad 7-segment display board

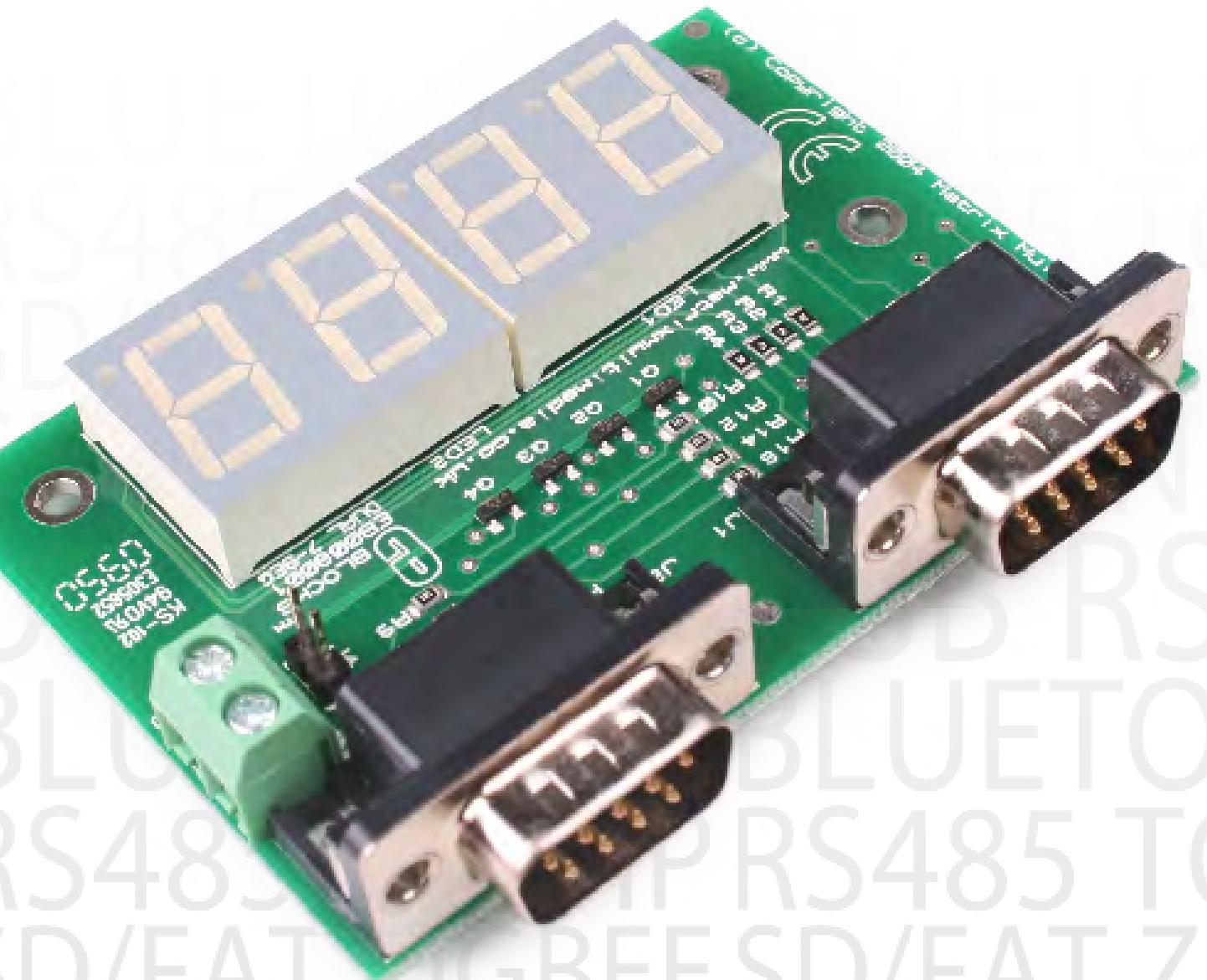

# Contents

About this document	3
Board layout	3
General information	4
Circuit description	4
Protective cover	5
Circuit diagram	6

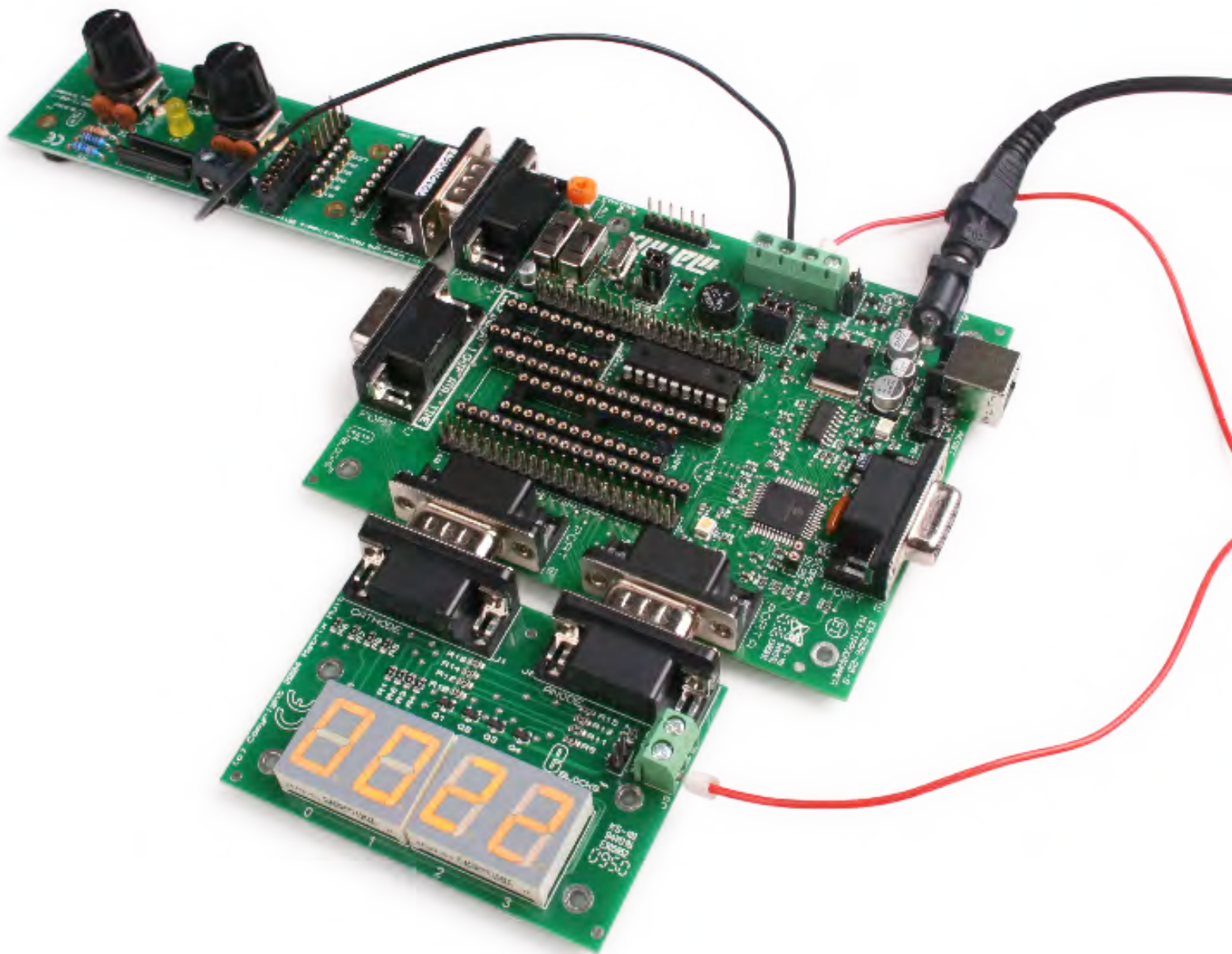

# About this document

This document concerns the EB008 E-blocks quad 7-segment display board.

## 1. Trademarks and copyright

PIC and PICmicro are registered trademarks of Arizona Microchip Inc. E-blocks is a trademark of Matrix Multimedia Ltd.

## 2. Disclaimer

The information provided within this document is correct at the time of going to press. Matrix Multimedia reserves the right to change specifications from time to time.

## 3. Testing this product

It is advisable to test the product upon receiving it to ensure it works correctly. Matrix provides test procedures

for all E-blocks, which can be found in the Support section of the website.

## 4. Product support

If you require support for this product then please visit the Matrix website, which contains many learning resources for the E-blocks series. On our website you will find:

- How to get started with E-blocks - if you are new to E-blocks and wish to learn how to use them from the beginning there are resources available to help.
- Relevant software and hardware that allow you to use your E-blocks product better.
- Example files and programs.
- Ways to get technical support for your product, either via the forums or by contacting us directly.

# Board layout

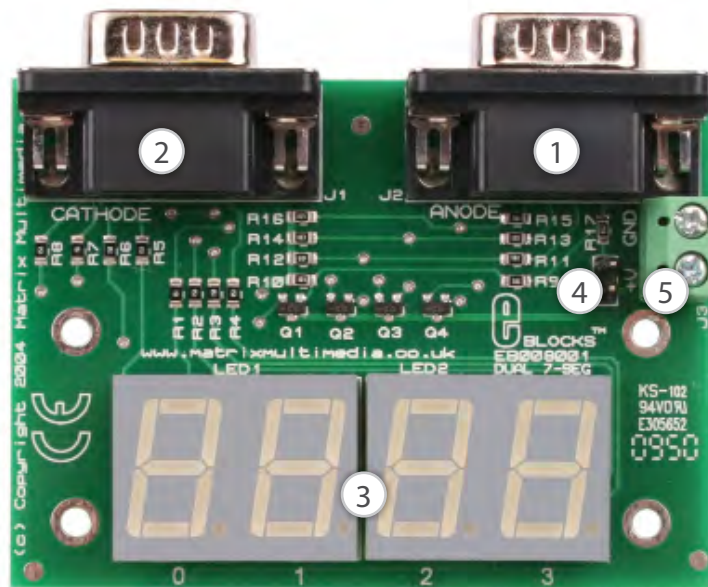

1. 9-way D-type plug - cathode
2. 9-way D-type plug - anode
3. Quad 7-segment
4. J4 - single display
5. Power screw terminal

# General information

This board provides a quad seven-segment common anode display, with an option to operate off only one port using links. This display requires two E-blocks ports to operate all four displays. If only one seven segment display is needed then only one E-block port is required and a jumper link of the board can be used to permanently engage one of the display digits.

## 1. Features

- E-blocks compatible
- Quad common anode displays

- Operational link allows operation from only one I/O port (two I/O ports required for full quad operation)
- Compatible with most I/O ports in the E-block range
- Ease to develop programming code using Flowcode icons
- 3.3 voltage compatible

## 2. Block schematic

Not supplied.

# Circuit description

The EB008 quad 7-segment display board circuit can be observed on page 6.

To use the full quad 7-segment displays the board must be connected to two I/O ports of an upstream board via connectors J1 and J2. Also note that the link (on J4) MUST NOT be connected. As there are not enough pins on the connectors, each of the 4 7-segment displays are turned on in sequence using connector J2 and the appropriate data on connector J1 is displayed. Connector J2 [Pins 1 (left display) - 4 (right display)] are used to select which of the four 7-seg display digits are active. The signals from J2 are buffered by NPN transistors which provide power for the anodes of each digit. The bits on connector J1 [Pins 1-8] connect to the cathodes of each segment and hence dictate which segments are lit. Note that each cathode must go low for the segment to light. For a program showing 4 digit numbers a multiplexing algorithm is required.

The device can still operate using only one I/O port connected to J1, but this only allows one (the far left) display to be operational. Placing a link on J4 will permanently power the anode of the left hand digit so that only cathode data is needed for the individual LEDs to illuminate. Again J1 dictates which segments are illuminated.

The board is usually operated off a +5V supply. This can easily be achieved by connecting a +5V supply via a wire into the screw terminals.

The diagram below shows which pins illuminate which corresponding segment in an individual digital display. Please note that in the E-block architecture than pin 1 will represent bit 0 of which ever port it is connected to.

## 1. 3.3V operation

This board is compatible with 3.3V systems.

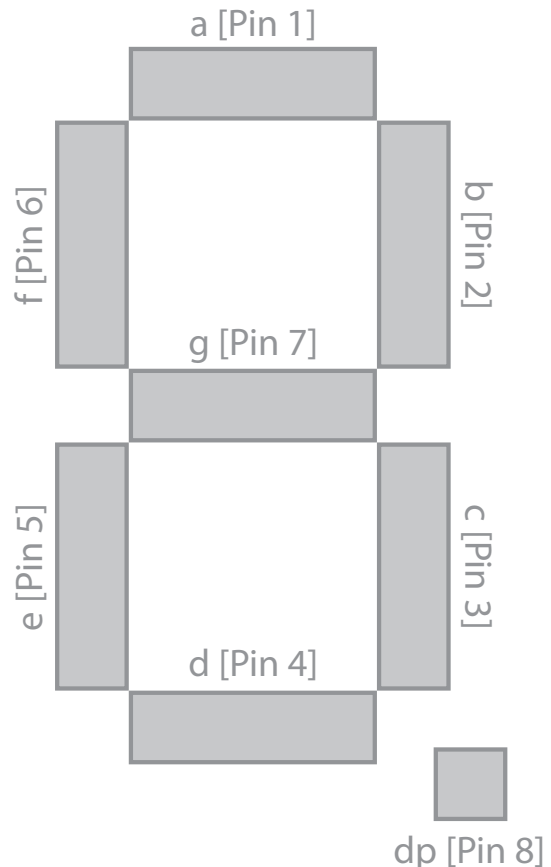

# Protective cover

Most of the boards in the E-blocks range can be fitted with a plastic cover as an optional extra. These covers are there to protect your E-blocks board therefore extending the life of the board. The covers also prevent the removal of external components while still allowing for the adjustment of applicable parts on the board.

12mm M3 spacers, anti-slip M3 nuts and 25mm M3 bolts can be used to attached the cover to the board. These are not included but can be bought separately from our website.

The order code for the EB008 quad 7-segment display board is EB708.

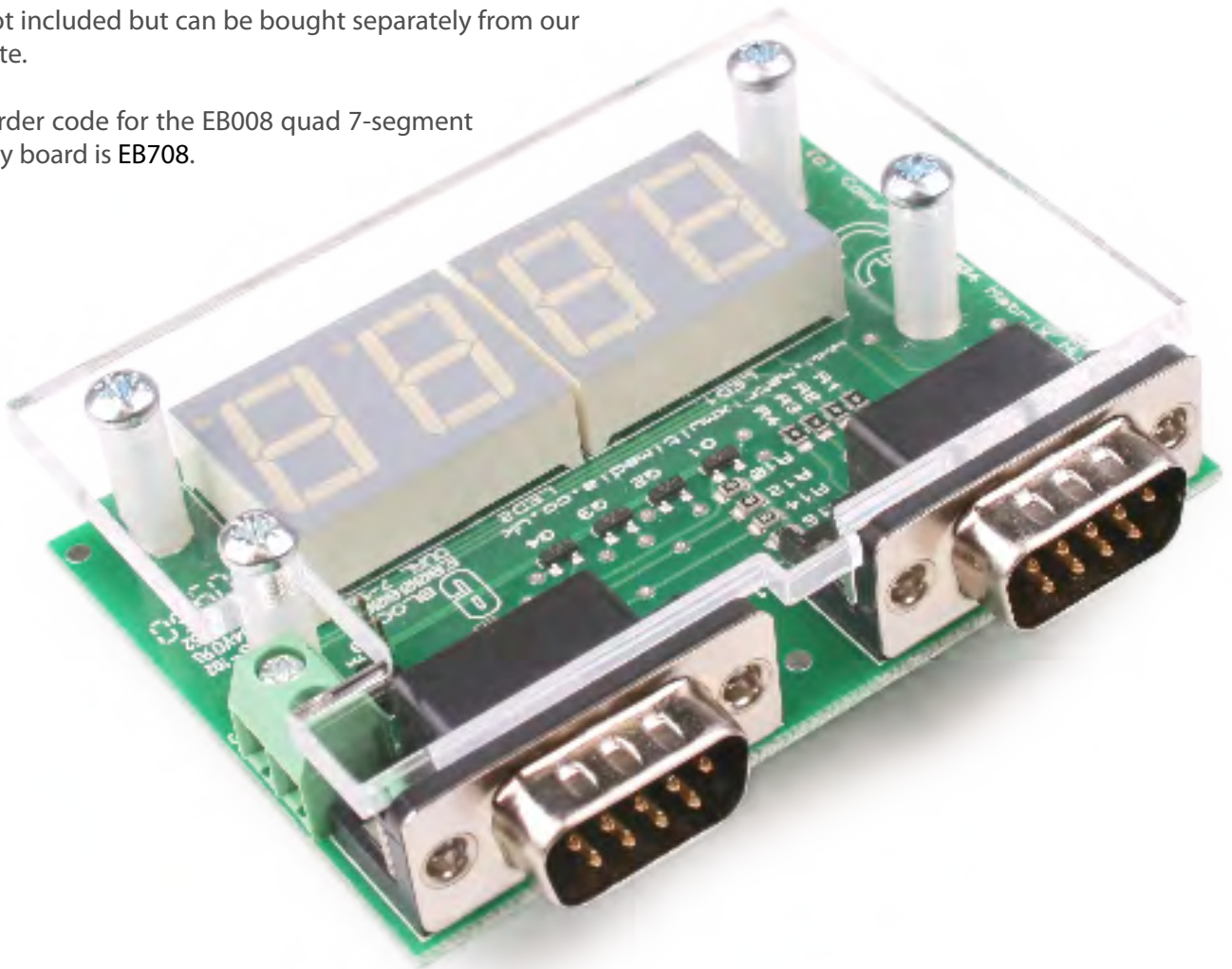

# Circuit diagram

THIS SYSTEM INCLUDES:-

- F1 FEET
- F2 FEET
- F3 FEET
- B1 BAG
- L1 LABEL

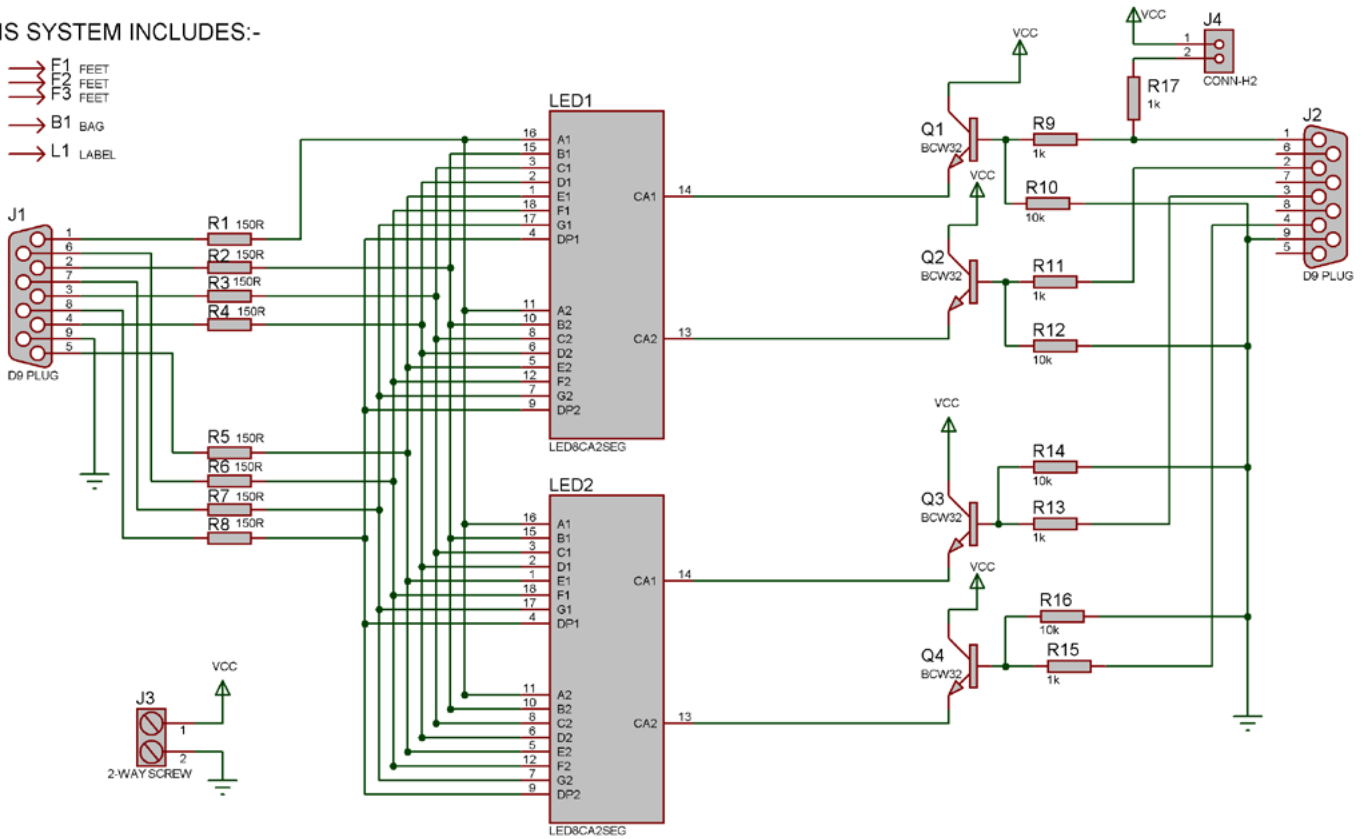



Matrix Multimedia Ltd.  
23 Emscote Street South  
Halifax  
HX1 3AN

t: +44 (0)1422 252380  
e: [sales@matrixmultimedia.co.uk](mailto:sales@matrixmultimedia.co.uk)

[www.matrixmultimedia.com](http://www.matrixmultimedia.com)

EB008-30-1