

Patch Board datasheet

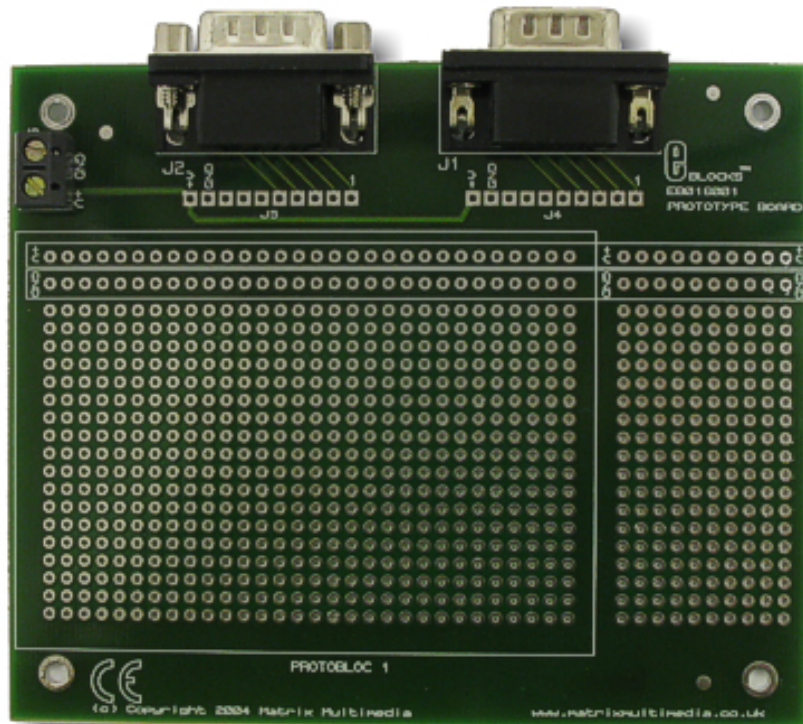
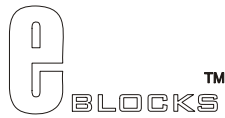

Contents

1. About this document
 2. General information
 3. Board Layout
 4. Circuit description
- Appendix
- o Circuit Diagram

1 About this document

This document concerns the Matrix Patch Board code EB-017-00-1.

Trademarks and Copyright

PIC, PICmicro are registered trademarks of Arizona Microchip Inc.

E-blocks is a trademark of Matrix Multimedia Limited.

EB-017-00-1 and associates software and documentation are Copyright ©2004 Matrix Multimedia Limited.

Other sources of information

There are various other documents and sources that you may find useful:

Getting started with E-Blocks.pdf

This describes the E-blocks system and how it can be used to develop complete systems for learning electronics and for PICmicro programming.

PPP Help file

This describes the PPP software and its functionality. PPP software is used for transferring hex code to a PICmicro microcontroller.

Disclaimer

The information in this document is correct at the time of going to press. Matrix Multimedia reserves the right to change specifications from time to time.

Technical support

If you have any problems operating this product then please refer to the troubleshooting section of this document first. You will find the latest software updates, FAQs and other information on our web site: www.matrixmultimedia.co.uk. If you still have problems please email us at: support@matrixmultimedia.co.uk. When emailing please state the operating system, the version of PPP you are using.

2 General information

Description

This E-block contains a small patch board for developing circuits and projects. Connectors for two E-block ports allows prototype wires and leads to be connected to the rows and columns on the prototype board.

This E-block is used where there is a requirement to set up semi-permanent dedicated E-blocks. This E-block is supplied in kit form – the D-type connectors need to be soldered into place.

Features

- 40 * 18 hole proto area
- Separate lines for power rails

3 Patch Board Layout

- 1) 9 Way D-type Socket
- 2) 9 Way D-type Socket
- 3) Screw Terminal
- 4) Pin connector for D-type socket
- 5) Pin connector for D-type socket
- 6) Patch area

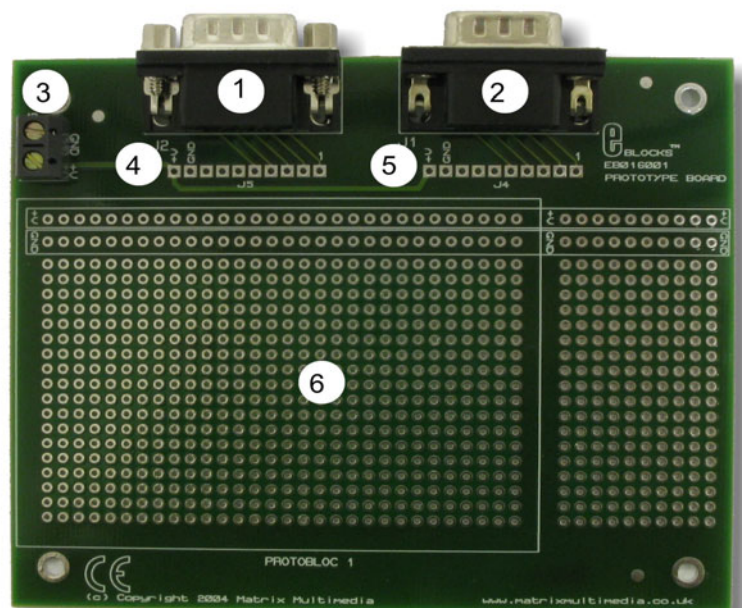

4 Circuit description

The Patch Board is simple to use. It is like any standard patch board. The patch area allows you to develop custom electronic projects on the grid network. It is then possible to connect any I / O to an upstream board via the Header pins which are connected directly to the associated 9-way D-type connector. Access to “+V” and “GND” can be made using wires from the header pins or there are dedicated lines. Although this does assume you have connected “+V” to the screw terminals.

Appendix 1 – Circuit Diagram

THIS SYSTEM INCLUDES:-

- FEET
- PROTOBLOC

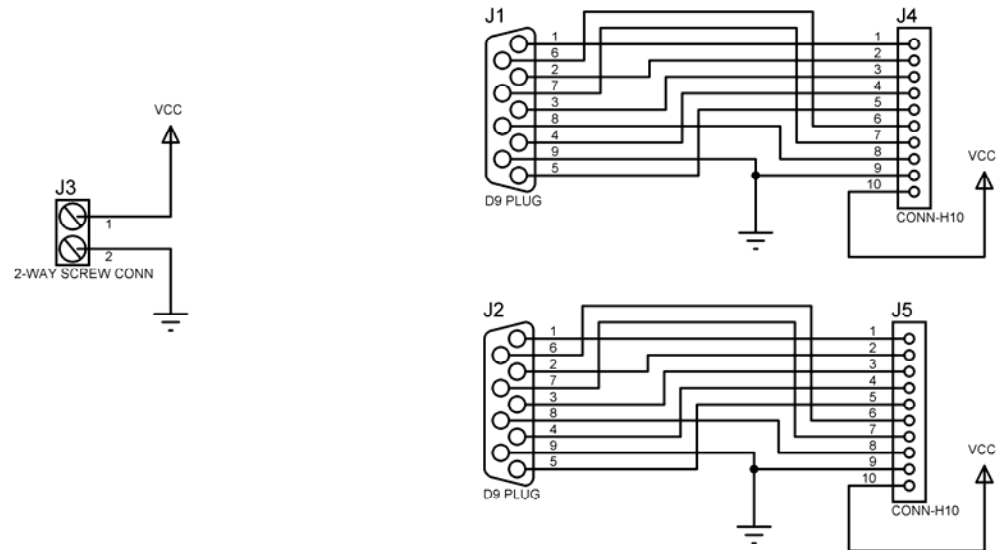

		MATRIX MULTIMEDIA LTD. www.matrixmultimedia.co.uk (c) Copyright 2004 Matrix Multimedia	
TITLE:		DATE:	
E-BLOCKS PATCH BOARD EB-017-00-1		22/03/05	
BY: Conor Carr		PAGE:	
REV: 1		1/1	